

Item Number
RAM-VB-162

RAM No-Drill™ Seat Bases

National Products, Inc.

Vehicle base for the CHRYSLER PT CRUISER (2001-2008)

SPECIFICATIONS

Placement

Passenger side on the floor, under seat

Drilling Required

None - uses existing seat bolts

Seat Configuration

Bucket

Construction/Finish

Steel/Black Powdercoat

Pole or Pedestal

Ordered Separately

Dimensions

A = 14.25", B = 18.125", C = 2.187"
D (Hole Center) = 13.75"

Weight

8.8 lbs.

Features

Installs in minutes with no drilling required
Won't interfere with levers or factory-installed console

Misc.

Rock solid construction
Lifetime warranty

National Products, Inc.
Phone: 206-763-8361
Fax: 206-763-9615
Address: 1205 S Orr St
Seattle, WA 98108
Website: www.ram-mount.com
Email: staff@ram-mount.com



Shown In Use

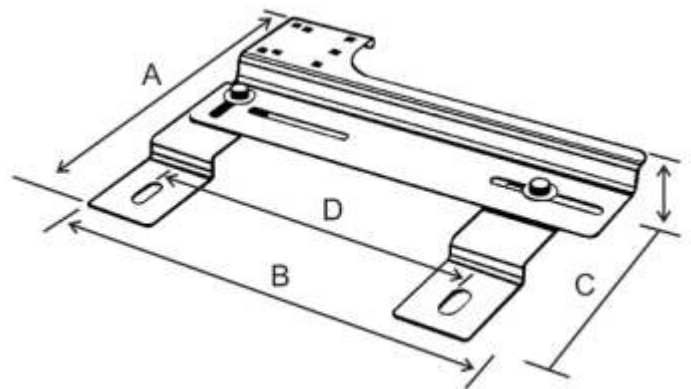

RAM-VB-162



Item Number
RAM-VB-162

RAM No-Drill™ Seat Bases
National Products, Inc.

Vehicle base for the CHRYSLER PT CRUISER (2001-2008)

INSTALLATION INSTRUCTIONS

Note: The telescoping pedestal in this system stops the glove compartment door just short of completely opening. It is still possible to easily reach completely in to the compartment. Total access is not prevented.

1. Move passenger side seat to its most rearward position.
2. Assemble the stamped metal base and two leg brackets. Place the leg brackets with the nut inserts underneath the metal base. There should be no gap between legs and base once completely assembled. Using the provided hardware, attach the legs loosely so they may slide. The leg closest to the center of the vehicle, platform side, aligns with the slot running the length of the car. The leg closest to the passenger door simply aligns with the outermost slot.
3. Place the male metal tube with square base over the mounting platform and assemble using the provided hardware. Tighten nuts fully.
4. Set aside this partially assembled No-Drill™ base.
5. Remove the drawer under the passenger seat and set aside.
6. Using a socket wrench, remove the two seat bolts located at the front of the passenger side seat. These hold the seat frame to the floor board.
7. Gently lift the front of the seat frame and slide the legs of the seat base between the frame and floor board. Align the rear most slots on the legs with the holes in the passenger side seat frame.
8. Using the longer replacement seat bolts and washers, reinsert the seat bolts so they pass through the seat frame, legs, and into the floor board.
9. Straighten the legs, and fully tighten the seat frame bolts.
10. Slide the metal base as far toward the back of the vehicle as possible while keeping it perpendicular to the seat rail legs. This keeps the telescoping pole from preventing access to the glove compartment.
11. Once base has been positioned properly, fully tighten hardware joining legs and base.
12. Replace drawer under seat. Once the track of the drawer is lined up with the track under the seat, gently press inward while lifting upward so the drawer clears the seat base and slides back under seat.



National Products, Inc.
Phone: 206-763-8361
Fax: 206-763-9615
Address: 1205 S Orr St
Seattle, WA 98108
Website: www.ram-mount.com
Email: staff@ram-mount.com

