

Item Number
RAM-VB-116

RAM No-Drill™ Seat Bases

National Products, Inc.

**Vehicle base for the
CHEVROLET COLORADO (2004-2011)
GMC CANYON (2004-2011)**

SPECIFICATIONS

Placement

Passenger side on the floor, in front of seat

Drilling Required

No - uses existing seat bolts

Pole or Pedestal

Ordered Separately

Seat Configuration

Bucket/Bench

Weight

10.7 lbs.

Construction/Finish

Steel/Black Powdercoat

Dimensions

A = 14", B = 4.75", C = 5.5", D = 17"

Hole Center = 11.75"

Tools required for base installation

18mm box end wrench, 18mm socket, universal joint adaptor or wobble, and socket wrench for base installation. Tools for complete system assembly: pliers, phillips screw driver, #10, 1/2", 9/16" box end wrench's.

Features

Installs in minutes with no drilling required
Angled step moves pole away from passenger leg space
Won't interfere with levers or factory-installed console or 4WD lever

Important Note

The RAM-VB-116 base will not fit crew cab vehicles where the vent duct passes under the front of the passenger seat. Consider attaching the riser to the no drill base prior to vehicle installation.

National Products, Inc.
Phone: 206-763-8361
Fax: 206-763-9615
Address: 8410 Dallas Ave S
Seattle, WA 98108
Website: www.ram-mount.com
Email: staff@ram-mount.com



Complete system
RAM-VB-116-SW1

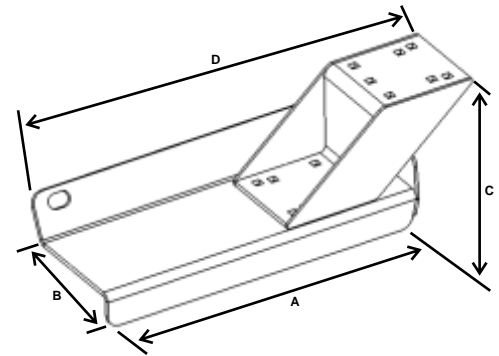

RAM-VB-116, SHOWN WITH
RAM-VB-SB4 RISER (INCLUDED)



Item Number
RAM-VB-116

RAM No-Drill™ Seat Bases
National Products, Inc.

Vehicle base for the
CHEVROLET COLORADO (2004-2011)
GMC CANYON (2004-2011)

INSTALLATION INSTRUCTIONS

Tools required for installation are an 18mm socket, and ½" box end wrench. You may also consider using a wobble adapter or universal joint style extension to aid in the installation of the hump side seat leg bolt.

1. Attach the adjustable riser to base with the provided carriage bolts, washers, and nuts. Use the ½" box end wrench to fully tighten the riser to the base.
2. Move the passenger seat to the rearmost setting.
3. Remove the front seat rail bolts that fasten the passenger seat brackets to the vehicle floor using the 18mm socket.
4. Pass the bolts you just removed through the holes in the No-Drill™ base.
5. Place the base with bolts over the seat frame legs, align the bolts with the holes, and start the thread by hand into the vehicle floor board.
6. Once both bolts have been started by hand, use the 18mm tools and fully tighten to 35 ft lbs.

National Products, Inc.
Phone: 206-763-8361
Fax: 206-763-9615
Address: 8410 Dallas Ave S
Seattle, WA 98108
Website: www.ram-mount.com
Email: staff@ram-mount.com

