

Item Number
RAM-VB-165

RAM No-Drill™ Seat Bases

National Products, Inc.

Vehicle base for the HUMMER H3 (2006-2009)

SPECIFICATIONS

Placement

Passenger side, in front, where seat frame meets floor board.

Drilling Required

None - uses existing seat bolts

Seat Configuration

Bucket

Pole or Pedestal

Ordered Separately

Construction/Finish

Steel/Black Powdercoat

Weight

4.3 lbs.

Dimensions

A = 16.125", B = 6.875", C = 3.25"
Hole Center = 11.8125"



Shown In Use

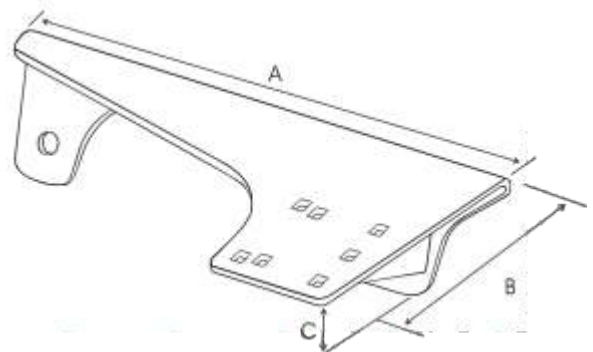

RAM-VB-165

Features

Installs in minutes with no drilling required

Misc.

Rock solid construction
Lifetime warranty

National Products, Inc.
Phone: 206-763-8361
Fax: 206-763-9615
Address: 1205 S Orr St
Seattle, WA 98108
Website: www.ram-mount.com
Email: staff@ram-mount.com



Item Number
RAM-VB-165

RAM No-Drill™ Seat Bases
National Products, Inc.

**Vehicle base for the
HUMMER H3 (2006-2009)**

INSTALLATION INSTRUCTIONS

Tools suggested for this installation are an 18MM socket wrench.

1. Using a socket wrench, remove the two seat rail bolts that hold the seat frame to the floor board. These are located at the bottom front of the passenger seat.
2. Once the seat bolts are removed, set them aside.
3. Place the No-Drill™ base with the mounting platform closest to the center hump.
4. Align the holes in the No-Drill™ base with those in the floor board.
5. Pass the factory seat rail bolts through the No-Drill™ base and partially re-thread them into the floor board by hand.
6. Once both bolts have been started by hand, use the socket wrench to re-tighten.

National Products, Inc.
Phone: 206-763-8361
Fax: 206-763-9615
Address: 1205 S Orr St
Seattle, WA 98108
Website: www.ram-mount.com
Email: staff@ram-mount.com

