

## Item Number \_\_\_\_\_

RAM-VB-110 & RAM-VB-110-SW1

# RAM No-Drill Seat Bases

National Products, Inc.

## Vehicle base for the

**Ford Expedition (1997-2012)**

**Ford F-150 (1997-2003)**

**Ford F-150 Heritage (2004)**

**Ford F-250 Light Duty (1997-2004)**

**Ford Windstar (2004-2007)**

## SPECIFICATIONS

### Placement

Passenger side floor board, under seat

### Tools required for base installation

18mm socket or T-55 torx for base installation. Tools for complete system assembly: pliers, phillips screw driver, #10, 1/2", 9/16" box end wrench's.

### Seat Configuration

Bucket/Bench

### Construction/Finish

Steel/Black Powdercoat

### Pole or Pedestal

Ordered Separately

### Weight

10.7 lbs.

### Dimensions

A = 15.25", B = 8", C = 2.5", D = 6.25,  
E = 19.75" Hole Center = 12.75"

## Notes.

One 4" riser is included with this vehicle base. Step feature allows minimized amount of intrusion of passenger leg space. This base will not interfere with factory installed console in most installations.

## Contact Information.

National Products, Inc.  
Phone: 206-763-8361  
Fax: 206-763-9615  
Address: 1205 S Orr St  
Seattle, WA 98108  
Website: [www.ram-mount.com](http://www.ram-mount.com)  
Email: [staff@ram-mount.com](mailto:staff@ram-mount.com)



RAM-VB-110-SW1

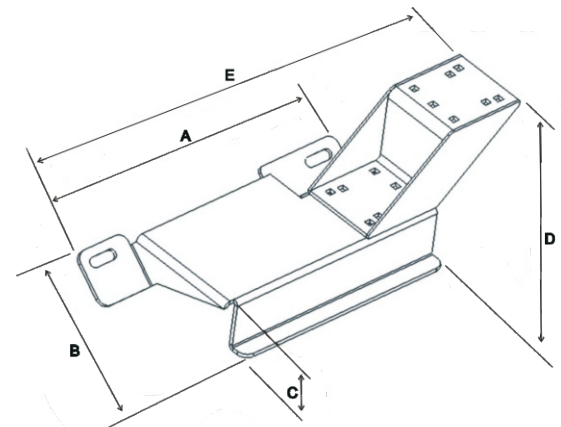

RAM-VB-110, SHOWN WITH  
RAM-VB-SB4 RISER (INCLUDED)



## **Item Number** \_\_\_\_\_

RAM-VB-110 & RAM-VB-110-SW1

# RAM No-Drill Seat Bases

National Products, Inc.

## **Vehicle base for the**

**Ford Expedition (1997-2012)**

**Ford F-150 (1997-2003)**

**Ford F-150 Heritage (2004)**

**Ford F-250 Light Duty (1997-2004)**

**Ford Windstar (2004-2007)**

## **INSTALLATION INSTRUCTIONS**

Kit includes longer seat leg bolts and stand offs for the 2008 and Newer Ford Expedition. These are not used on any other vehicles listed. Use factory hardware and instructions below for all other vehicles.

1. Attach the RAM-VB-SB4 riser to base with the provided carriage bolts, washers, and nuts tightening with the ½" box end wrench.
2. Move the passenger seat to the rearmost setting.
3. Remove the front seat rail bolts that fasten the passenger seat brackets to the vehicle floor using the 18mm or T55 torx bit.
4. Without moving the seat, place the base over the front of the seat bracket.
5. Re-install the seat bolts through the base, then the seat frame legs, and into the vehicle floor board. Start the thread by hands. Fully tighten / torque the seat leg bolts to 39 ft lbs.

Note that for the 2008 and newer Expedition, the stand off kit included will be necessary for installation. The longer seat leg bolts and short sections of steel tubing allow for angle correction in these models. Place the stand offs in between the No-Drill™ base and the seat legs and pass the longer bolts with washers through and start the thread by hand. Fully tighten as stated in step 5 above.

For bench seat models, the installer will need to expose the mounting hole under the carpet or vinyl flooring. Place the laptop base so that the door side seat leg bolt and door side mounting hole on the base are lined up. Use a pencil or chalk to mark the location under the hump side seat bolt hole of the laptop base. It is sometimes possible to feel the mounting hole through the floor covering. Using a sharp tool or knife, cut a u-shaped flap approximately 1.5" wide where the mark was made to expose the mounting point in the floor board.

National Products, Inc.  
Phone: 206-763-8361  
Fax: 206-763-9615  
Address: 1205 S Orr St  
Seattle, WA 98108  
Website: [www.ram-mount.com](http://www.ram-mount.com)  
Email: [staff@ram-mount.com](mailto:staff@ram-mount.com)

